

MEPC121 – Spread Controller



- Proportional control for up to 2 hydraulic solenoid coils
- ON/OFF control for up to 2 lightings
- Adjustable maximum and minimum output current
- Adjustable ramp up/down
- Adjustable dither frequency

1. Description

MEPC121 spread controller provides stable proportional control with its adjustable maximum and minimum output current, ramp up/down and dither frequency for 2 hydraulic solenoid coils. In addition to proportional control, MEPC121 also provides ON/OFF control for up to 2 lightings.

2. Area of use

- Road maintenance vehicles
- Municipal vehicles
- Agricultural and forestry machines
- Construction trucks

3. Technical data

	Unit	Description, value
Supply voltage	V DC	10-30
Dimensions	mm	132 x 132 x 103
Connection type		16-pin connector
Protection class		IP 51
Outputs	A	Solenoid coils (proportional): 2 x 2,5 (max.) Lightings: 2 x 2,5 (max.)
Dither frequency	Hz	Programmable in the interval [100, 500]. Please contact supplier.

4. Functions

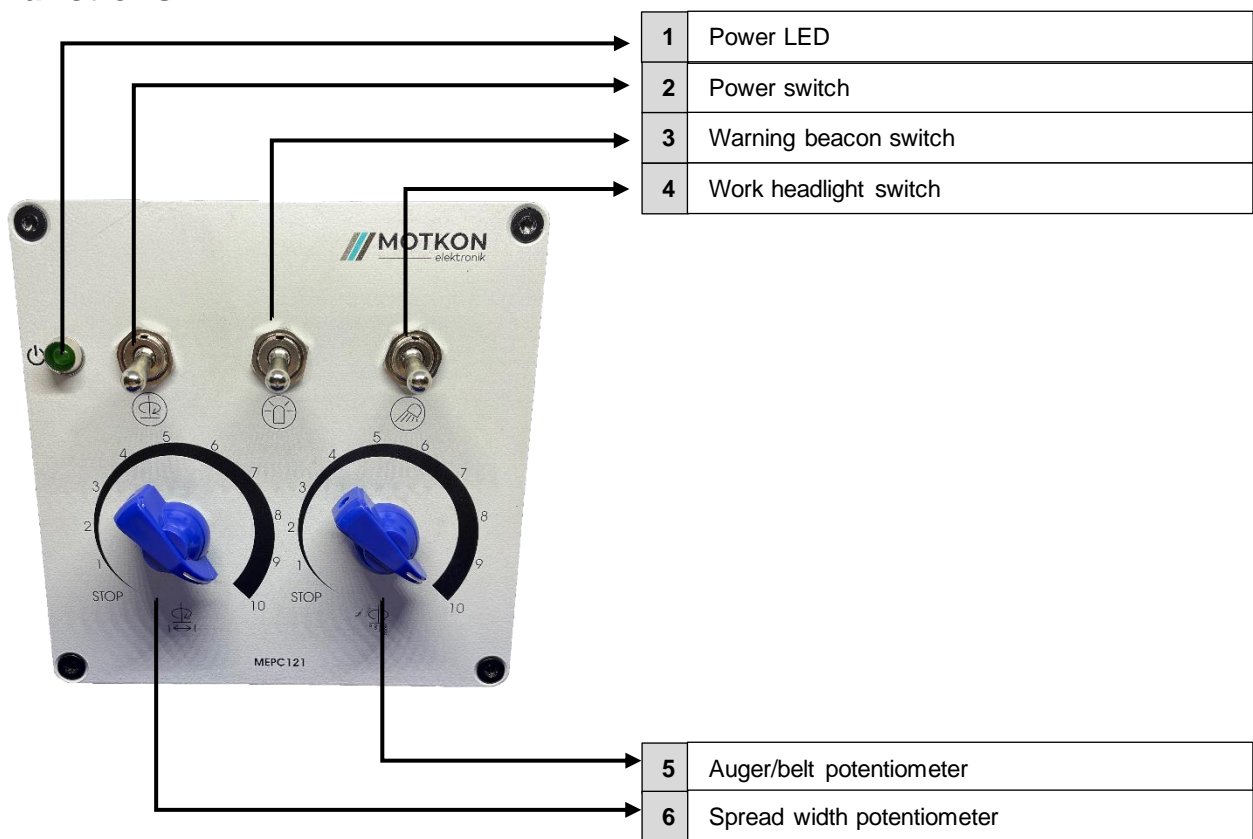

5. Connections

Pin Number	Connection	Pin Number	Connection
1	Spread width solenoid	9	n/a
2	Spread width solenoid	10	Warning Beacon GND (-)
3	Auger/belt solenoid	11	Work headlight GND (-)
4	Auger/belt solenoid	12	GND (-)
5	Warning beacon (+)	13	n/a
6	Work headlight (+)	14	n/a
7	n/a	15	Main Vcc (+)
8	n/a	16	Main GND (-)

Wiring diagram

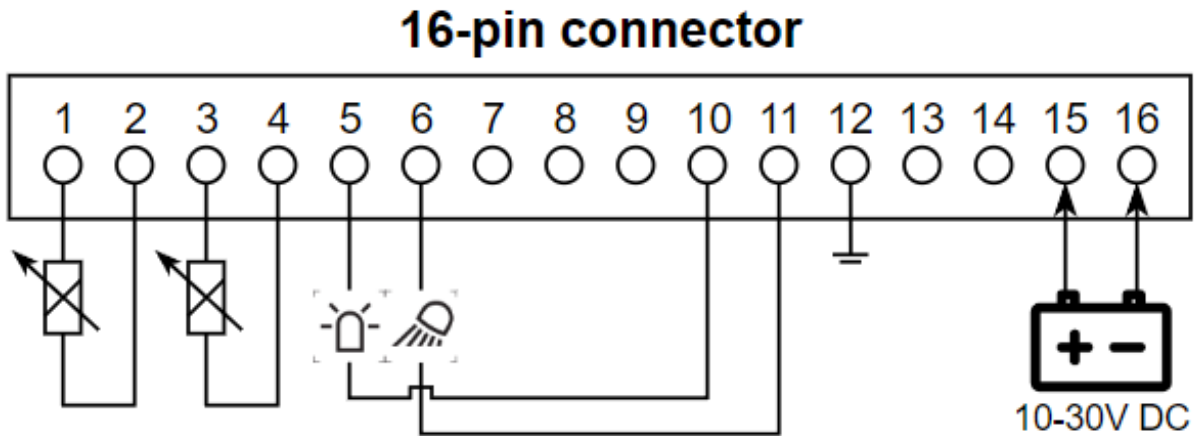

info@motkon.com

www.motkon.com

© 2022 Motkon Elektronik, Ankara

All rights reserved.

Data is provided for product description only, and must not be interpreted as warranted characteristics in the legal sense. The information should not relieve users from the duty of conducting their own tests and evaluations.

